

Mini-spectrometer

[**Micro series**]

C12666MA



Fingertip size, ultra-compact spectrometer head integrating MEMS and image sensor technologies

The C12666MA is an ultra-compact (Fingertip size) spectrometer head developed based on our MEMS and image sensor technologies. The adoption of a newly designed optical system has achieved a remarkably small size, less than half the volume of the previous mini-spectrometer MS series (C10988MA-01). In addition, the employment of hermetic packaging has improved humidity resistance.

This product is suitable for integration into a variety of devices, such as integration into printers and hand-held color monitoring devices that require color management. It is also suitable for applications that collaborate with portable devices, such as smartphones and tablets.

Features

- **Fingertip size: 20.1 × 12.5 × 10.1 mm**
- **Weight: 5 g**
- **Spectral response range: 340 to 780 nm**
- **Spectral resolution: 15 nm max.**
- **Hermetic package: High reliability against humidity**
- **Installation into mobile measurement equipment**
- **Wavelength conversion factor*1 is listed on final inspection sheet**

*1: A conversion factor for converting the image sensor pixel number into a wavelength. A calculation factor for converting the A/D converted count into the input light level is not provided.

Applications

- **Color monitoring for printers and printing machines**
- **Testers for lights and LEDs**
- **Color adjustment of various large size displays**
- **Water quality control monitors and other environment measuring instruments**
- **Measuring instruments that use portable devices such as smartphones and tablets**

Optical characteristics

Parameter	Value	Unit
Spectral response range	340 to 780	nm
Spectral resolution (FWHM)	Typ.	12
	Max.	15
Wavelength reproducibility*2	-0.5 to +0.5	nm
Wavelength temperature dependence	-0.1 to +0.1	nm/°C
Spectral stray light*3	-25	dB

*2: Measured under constant light input conditions

*3: Spectral stray light = $10 \times \log (Tl/Th)$

Th: output signal when a light spectrum at a certain wavelength is input

Tl: output signal at that wavelength ± 40 nm

Electrical characteristics

Parameter	Min.	Typ.	Max.	Unit
Supply voltage	4.75	5	5.25	V
Power consumption	-	30	-	mW
Video rate	0.25	-	200	kHz
Output impedance	-	150 *4	-	Ω

*4: An increase in the current consumption at the video output terminal also increases the chip temperature and so causes the dark current to rise. To avoid this, connect a buffer amplifier for impedance conversion to the video output terminal so that the current flow is minimized. As the buffer amplifier, use a JFET or CMOS input operational amplifier of optical input impedance.

Structure

Parameter	Specification	Unit
Dimensions (W × D × H)	20.1 × 12.5 × 10.1	mm
Weight	5	g
Slit*5 (H × V)	50 × 750	μm
NA*6	0.22	-
Image sensor (H × V)	CMOS linear image sensor with a slit	-
Number of pixels	256	pixels
Pixel size (H × V)	12.5 × 1000	μm

*5: Entrance slit aperture size

*6: Numeric aperture (solid angle)

Absolute maximum ratings

Parameter	Value	Unit
Operating temperature*7	+5 to +50	°C
Storage temperature*7	-20 to +70	°C

*7: No dew condensation

When there is a temperature difference between a product and the surrounding area in high humidity environment, dew condensation may occur on the product surface. Dew condensation on the product may cause deterioration in characteristics and reliability.

Note: Exceeding the absolute maximum ratings even momentarily may cause a drop in product quality. Always be sure to use the product within the absolute maximum ratings.

Optical component layout

Besides a CMOS image sensor chip integrated with an optical slit by etching technology, the C12666MA employs a reflective concave blazed grating formed by nanoimprint. In addition, the glass used in the light path of the previous C10988MA-01 is not used in the C12666MA, making it extremely compact.

Structure

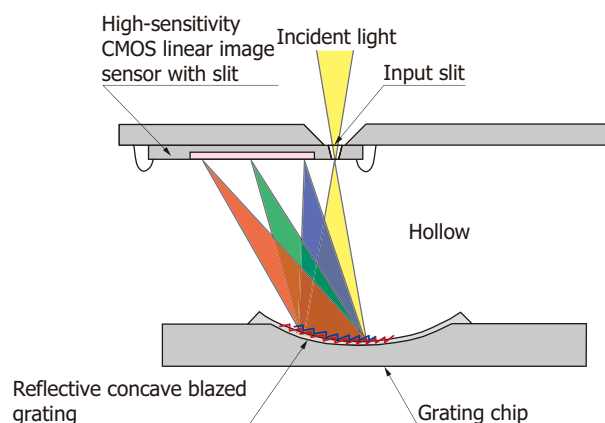

KACCC0757EB



CMOS linear image sensor with a slit [Incident light side (back of chip)]

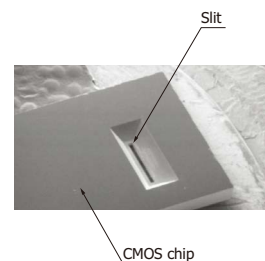

Spectral response (typical example)

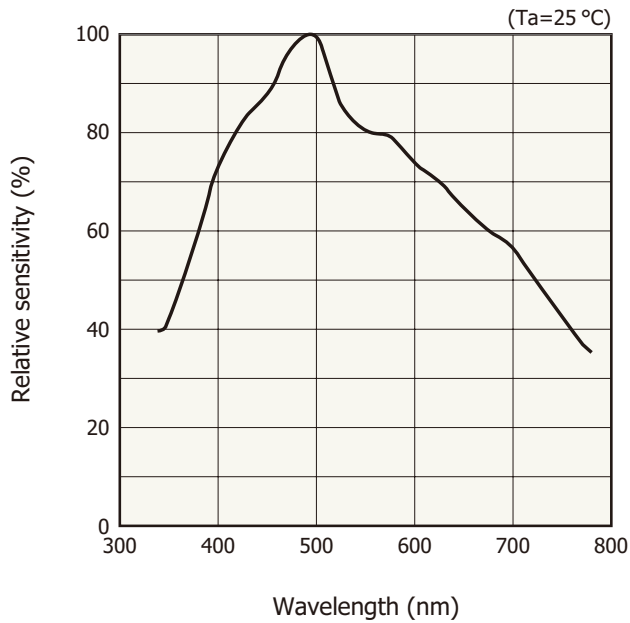

KACCB0350EB

Spectral resolution vs. wavelength (typical example)

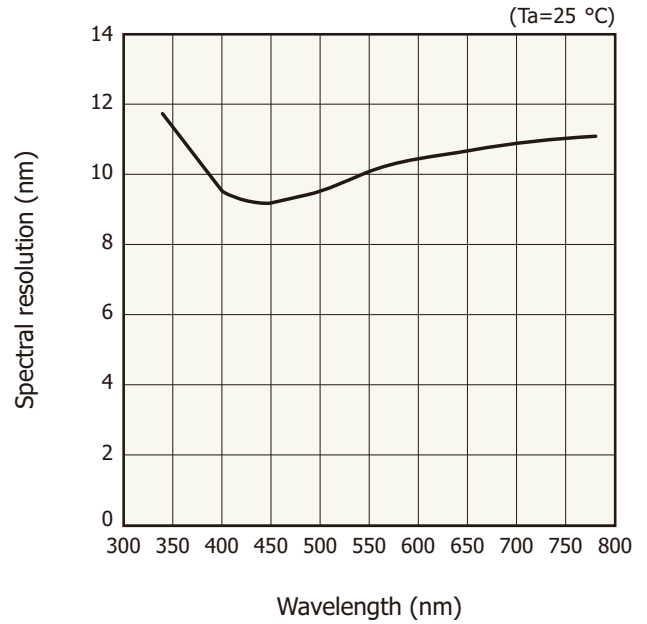

KACCB0351EA

Linearity (typical example)

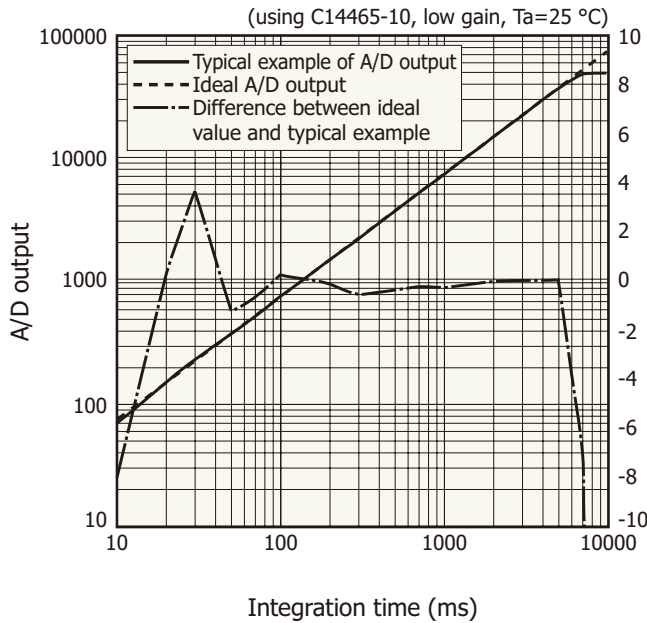

Difference between ideal value and typical example (%)

Dark output vs. ambient temperature (typical example)

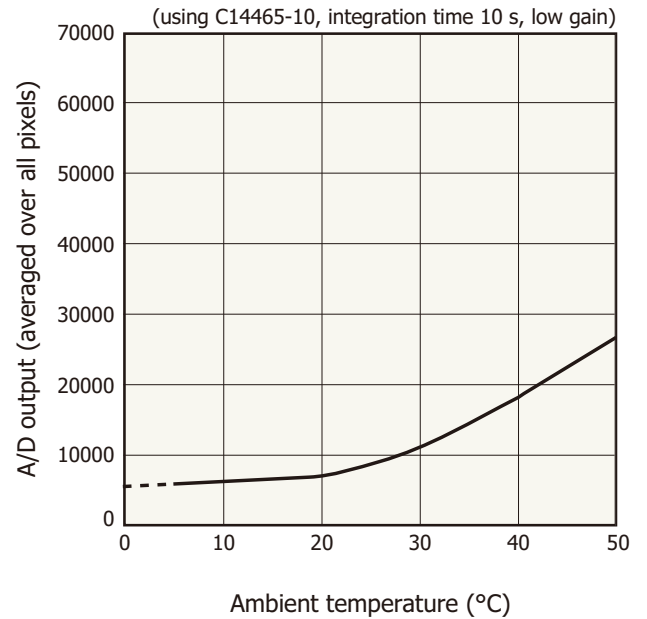

A/D output is the output with dark output is subtracted when light is input. The difference between the ideal value and typical example contains a measurement error. The smaller the A/D output, the larger the measurement error.

KACCB0352EC

A/D output is the sum of the sensor and circuit offset outputs and the sensor dark output.

KACCB0354EC

Measurable incident light level

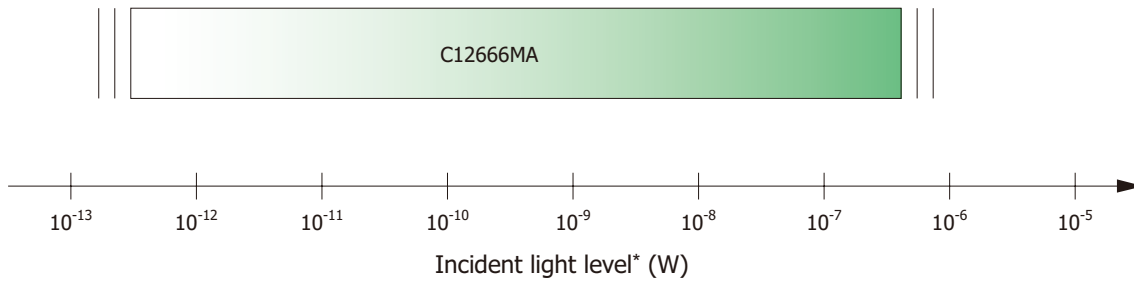

* Input spot diameter: 800 μm ($\lambda=550\text{ nm}$)

KACCB354EA

Recommended driver circuit example

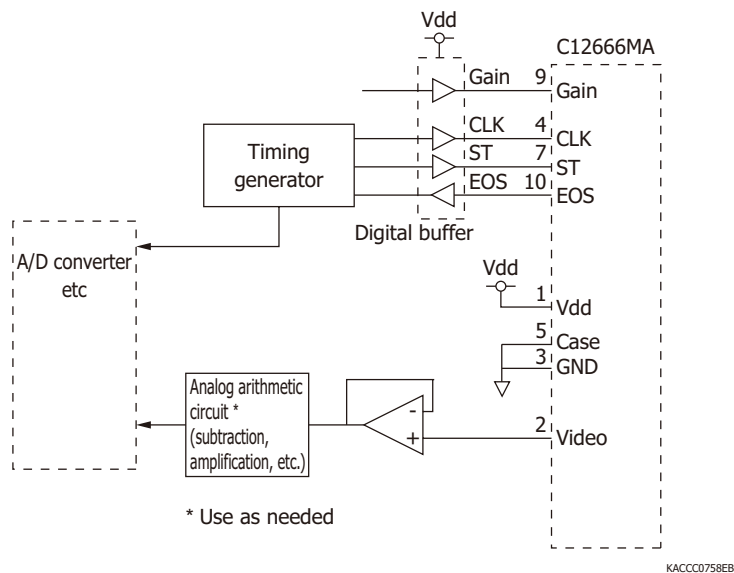

Precautions

- The packaging of C12666MA is electrically conductive, so be careful when designing the circuit to avoid short circuit caused by contact with a circuit pattern.
- If external force is repeatedly applied to the lead pins, this may damage the lead pins.
- To prevent damage due to soldering, be careful of the soldering temperature and time.
As a general guide, finish soldering within 3.5 seconds at 350 °C or less when soldering by hand, or within 10 seconds at 260 °C or less when using a solder bath.

Dimensional outline
(unit: mm, tolerance unless otherwise noted: ±0.2)

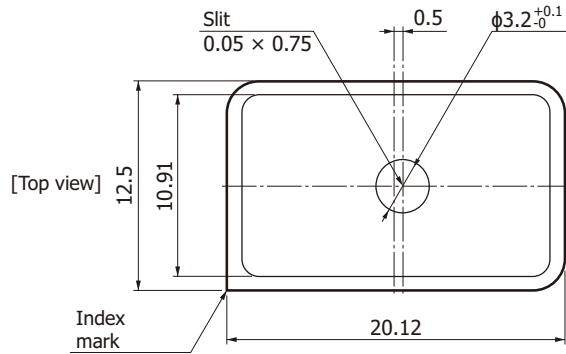

Enlarged view of slit (unit: mm)

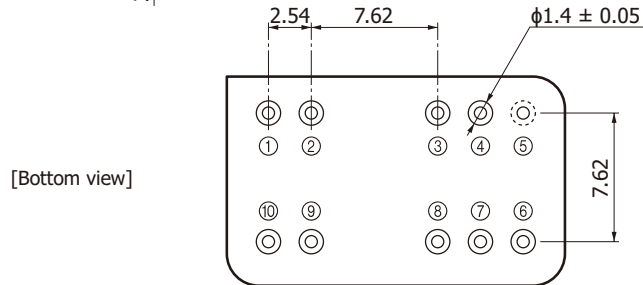
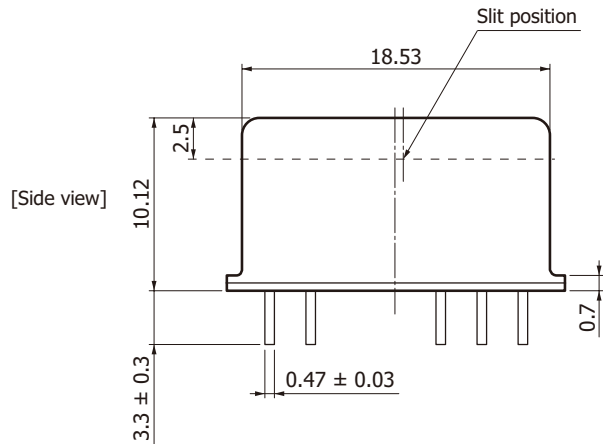
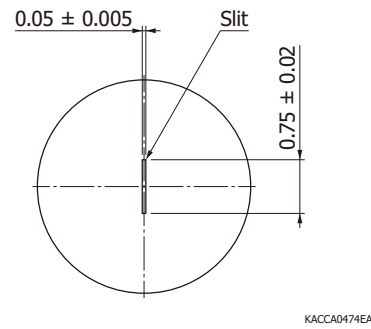

- ① Vdd
- ② Video
- ③ GND
- ④ CLK
- ⑤ Case
- ⑥ NC
- ⑦ ST
- ⑧ NC
- ⑨ Gain
- ⑩ EOS

KACCA0336EB

Pin connections

Make electrical connections to an external circuit using leads.

Pin no.	Symbol	Name	I/O	Description
1	Vdd	Supply voltage	I	Image sensor power supply: 5 V
2	Video	Video output	O	Video output signal
3	GND	Ground	-	Sensor ground
4	CLK	Clock pulse	I	Sensor scan sync signal
5	Case	Case	-	Case connection terminal
6	NC		-	No connection
7	ST	Start pulse	I	Start pulse
8	NC		-	No connection
9	Gain	Gain	I	Image sensor: Gain setting
10	EOS	End of scan	O	Sensor scan end signal

Note: Pin no. 9 is pulled up internally to Vdd via 10 kΩ.

Do not pull-up or pull-down the gain setting using an external circuit. For low gain, leave the pin open or connect to Vdd. For high gain, connect to GND.

Internal CMOS image sensor specifications

Recommended terminal voltage

Parameter	Symbol	Min.	Typ.	Max.	Unit
Supply voltage	Vdd	4.75	5	5.25	V
Gain selection terminal voltage	High gain	0	-	0.4	V
	Low gain	Vdd - 0.25	Vdd	Vdd + 0.25	V
Clock pulse voltage	High level	Vdd - 0.25	Vdd	Vdd + 0.25	V
	Low level	0	-	0.4	V
Start pulse voltage	High level	Vdd - 0.25	Vdd	Vdd + 0.25	V
	Low level	0	-	0.4	V

Electrical characteristics [Ta=25 °C, Vdd=5 V, V(CLK)=V(ST)=5 V]

Parameter	Symbol	Min.	Typ.	Max.	Unit
Clock pulse frequency	f(CLK)	1	-	800	kHz
Power consumption	High gain	-	-	60	mW
	Low gain	-	-	60	

Electrical and optical characteristics [Ta=25 °C, Vdd=5 V, V(CLK)=V(ST)=5 V]

Parameter	Symbol	Min.	Typ.	Max.	Unit
Dark current	High gain	-	0.02	0.08	pA
	Low gain	-	0.02	0.08	
Output offset voltage	High gain	0.15	0.35	0.55	V
	Low gain	0.15	0.35	0.55	
Charge amplifier feedback capacitance*8	High gain	-	1.4	-	pF
	Low gain	-	4.8	-	
Saturation output voltage*9	High gain	2.3	2.8	3.3	V
	Low gain	1.4	1.7	2.0	
Readout noise	High gain	-	0.3	0.5	mV rms
	Low gain	-	0.2	0.4	

*8: Gain=5 V (low gain), Vg=0 V (high gain)

*9: Voltage difference relative to Vo

Timing chart

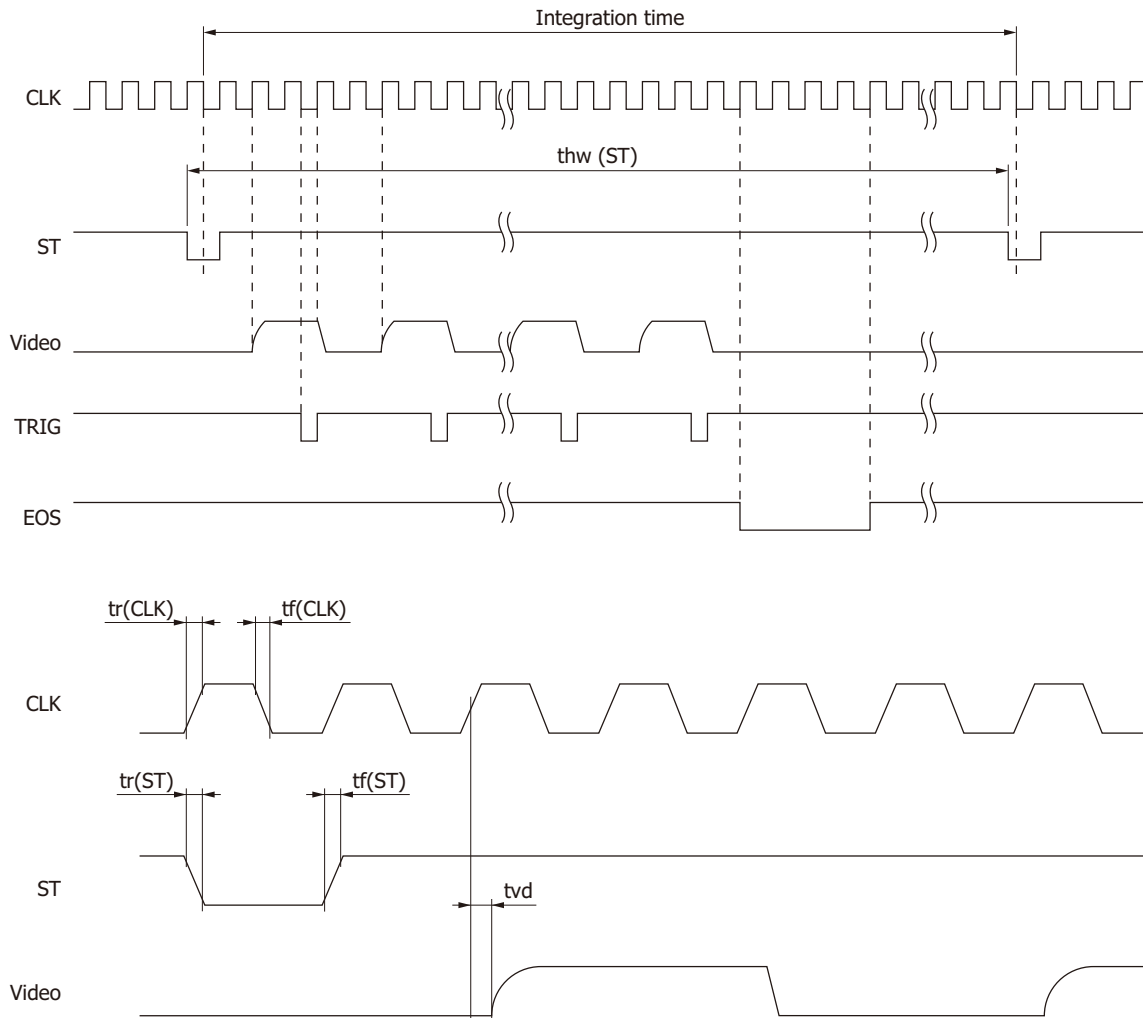

KACCC0493EB

Parameter	Symbol	Min.	Typ.	Max.	Unit
Start pulse high period	$thw(ST)$	$1030/f(CLK)$	-	-	s
Start pulse rise/fall times	$tr(ST), tf(ST)$	0	20	30	ns
Clock pulse duty ratio	-	45	50	55	%
Clock pulse rise/fall times	$tr(CLK), tf(CLK)$	0	20	30	ns
Video delay time	tvd	-	20	-	ns

Note: The clock pulse should be set from high to low just once when the start pulse is low. The internal shift register starts operating at this timing.

The integration time is determined by the start pulse intervals. However, since the charge integration of each pixel is carried out between the signal readout of that pixel and the next signal readout of the same pixel, the start time of charge integration differs depending on each pixel. In addition, the next start pulse cannot be input until signal readout from all pixels is completed.

Video output is 1/4 of the clock pulse frequency.

Selection chart

A mini-spectrometer with SMA connector (for optical fiber connection), an evaluation circuit, and a driver circuit are available as related products for the mini-spectrometer (micro series).

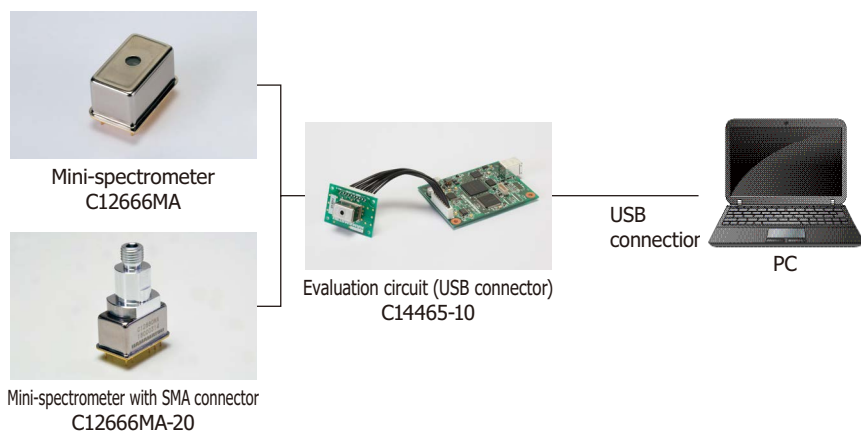

KACCC1247EA

Mini-spectrometer with SMA connector C12666MA-20

The C12666MA-20 is a product in which an SMA connector is attached to the C12666MA. It has an optical system inside the connector that can be connected with an optical fiber (single core, NA=0.22) with an SMA connector. The specifications of the C12666MA-20 is the same as those of the C12666MA except the connector section.



Dimensional outline (unit: mm)

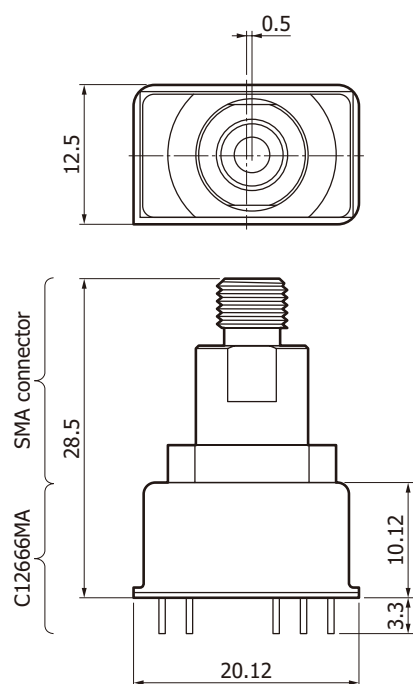

Tolerance unless
otherwise noted: ± 0.2

KACCA0507EA

Options

Product name	Type no.	Core diameter (μm)	Specification
Fiber for UV/visible range (resistance to UV)	A16962-01	600	NA=0.22, length=1.5 m With SMA905D connector on each end

Mini-spectrometer evaluation circuit C14465-10 (sold separately)

The C14465-10 is a circuit board designed to simply evaluate the characteristics of the mini-spectrometer. The characteristics of the mini-spectrometer can be evaluated using the evaluation software by connecting the mini-spectrometer to a PC with a USB cable A9160 (AB type, sold separately)*10.



Features

- Initial evaluation circuit for mini-spectrometer*11
- Wavelength conversion factors of the mini-spectrometer can be input from a PC.*12
- High A/D resolution (16-bit)
- USB powered

*10: Compatible OS:

Microsoft® Windows® 11 Professional

*11: The C14465-10 is a modified version of the C14465 evaluation circuit for the previous mini-spectrometer MS series (C10988MA-01, C11708MA). Only the sensor board has been modified. If you already have the C14465, you only have to purchase the C14465-03 (the sensor board for mini-spectrometers) to evaluate C12666MA mini-spectrometers.

*12: A typical wavelength conversion factor is entered at the time of shipment of the C14465-10. To measure a spectrum with higher wavelength accuracy, it is necessary to input the wavelength conversion factor listed in the final inspection sheet that comes with each mini-spectrometer.

Note: Microsoft and Windows are registered trademarks of Microsoft Corporation in the United States and/or other countries.

Electrical characteristics

Parameter	Specification	Unit
Interface	USB 2.0	-
A/D conversion	16	bit
Clock pulse frequency	800	kHz
Video rate	200	kHz
Integration time	5 to 10000	ms

Structure

Parameter	Specification	Unit
Applicable spectrometer	C12666MA	-
Dimensions	Control board	80 × 60
	Sensor board	30 × 44

Absolute maximum ratings

Parameter	Value	Unit
Operating temperature*13	+5 to +40	°C
Storage temperature*13	-20 to +70	°C

*13: No dew condensation

When there is a temperature difference between a product and the surrounding area in high humidity environment, dew condensation may occur on the product surface. Dew condensation on the product may cause deterioration in characteristics and reliability.

Note: Exceeding the absolute maximum ratings even momentarily may cause a drop in product quality. Always be sure to use the product within the absolute maximum ratings.

Connection example

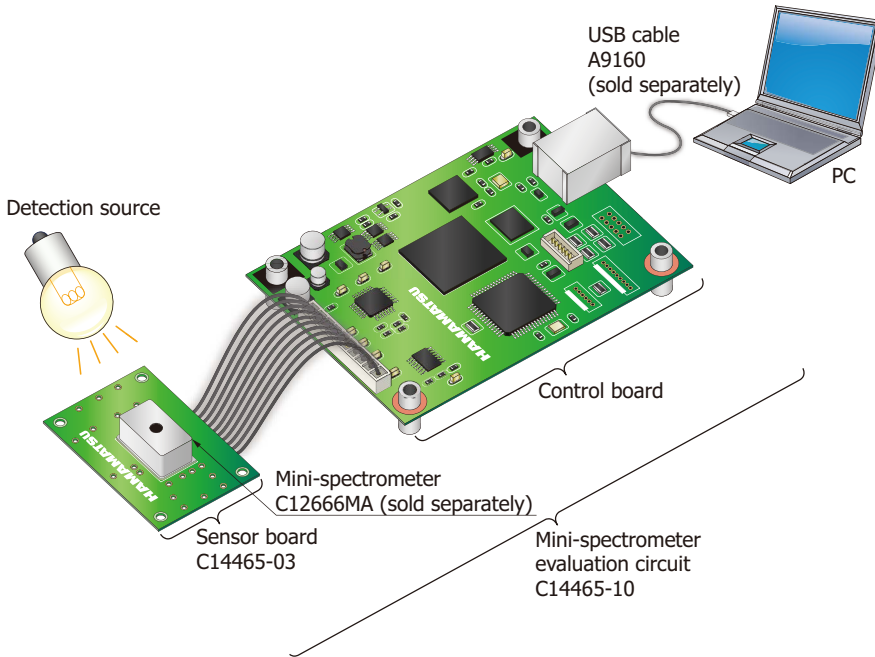

KACCC0759ED

Evaluation software display example

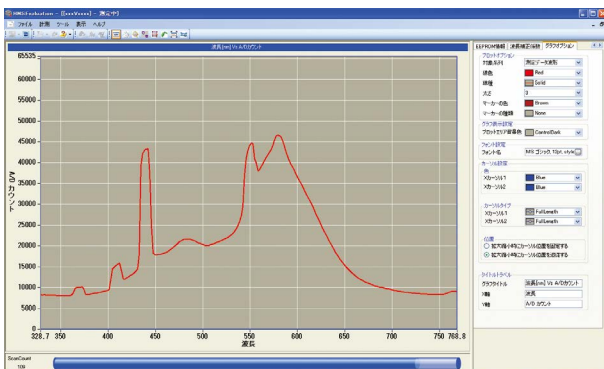

Related information

www.hamamatsu.com/sp/ssd/doc_en.html

- Precaution
- Disclaimer

- Catalogs
- Technical note / Mini-spectrometer

Information described in this material is current as of February 2026.

Product specifications are subject to change without prior notice due to improvements or other reasons. This document has been carefully prepared and the information contained is believed to be accurate. In rare cases, however, there may be inaccuracies such as text errors. Before using these products, always contact us for the delivery specification sheet to check the latest specifications.

The product warranty is valid for one year after delivery and is limited to product repair or replacement for defects discovered and reported to us within that one year period. However, even if within the warranty period we accept absolutely no liability for any loss caused by natural disasters or improper product use. Copying or reprinting the contents described in this material in whole or in part is prohibited without our prior permission.